

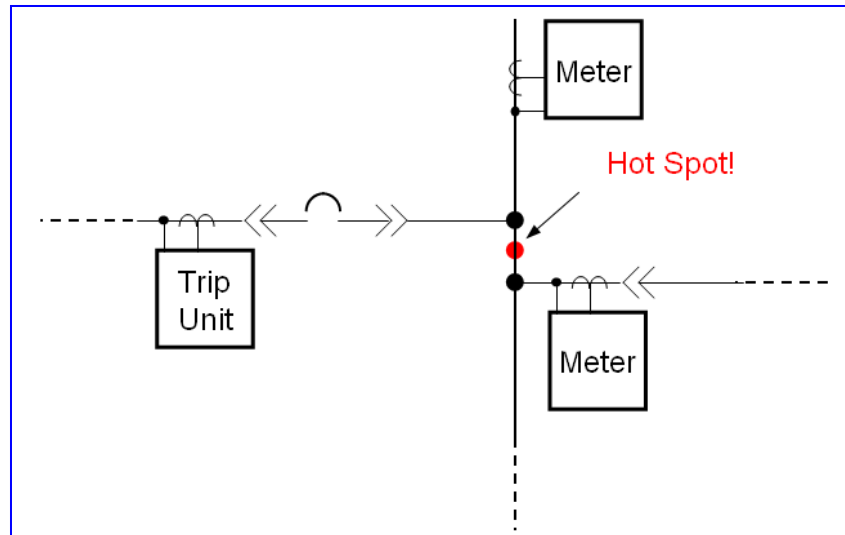

# Data Analysis Finds Hidden Information in Electrical Systems

Dave Loucks, P.E., Eaton Corporation

# Locating High Impedance Junctions



**Figure 1: High resistance junction creates “hot spots”**

- A high impedance connection or “hot spot” can appear anywhere there is a transition between two conductors (splice on bus, cable and compression fitting, two breaker contacts, etc.)
- This higher impedance (actually resistance) junction creates higher temperatures due to greater energy losses ( $E = I^2R$ ).

# How Are Hot Spots Detected Today?

---

- Contact temperature sensors
- IR measurement (pyrometer or IR photography)
- Fiber distributed temperature sensing (DTS)
- Offline resistance measurements using current injection

## Note:

Direct temperature sensing requires placing sensors near potential hotspots. Current injection using offline measurements will not represent actual system conditions since power must be removed from the circuit and parts allowed to cool.

# Potential Problem Areas

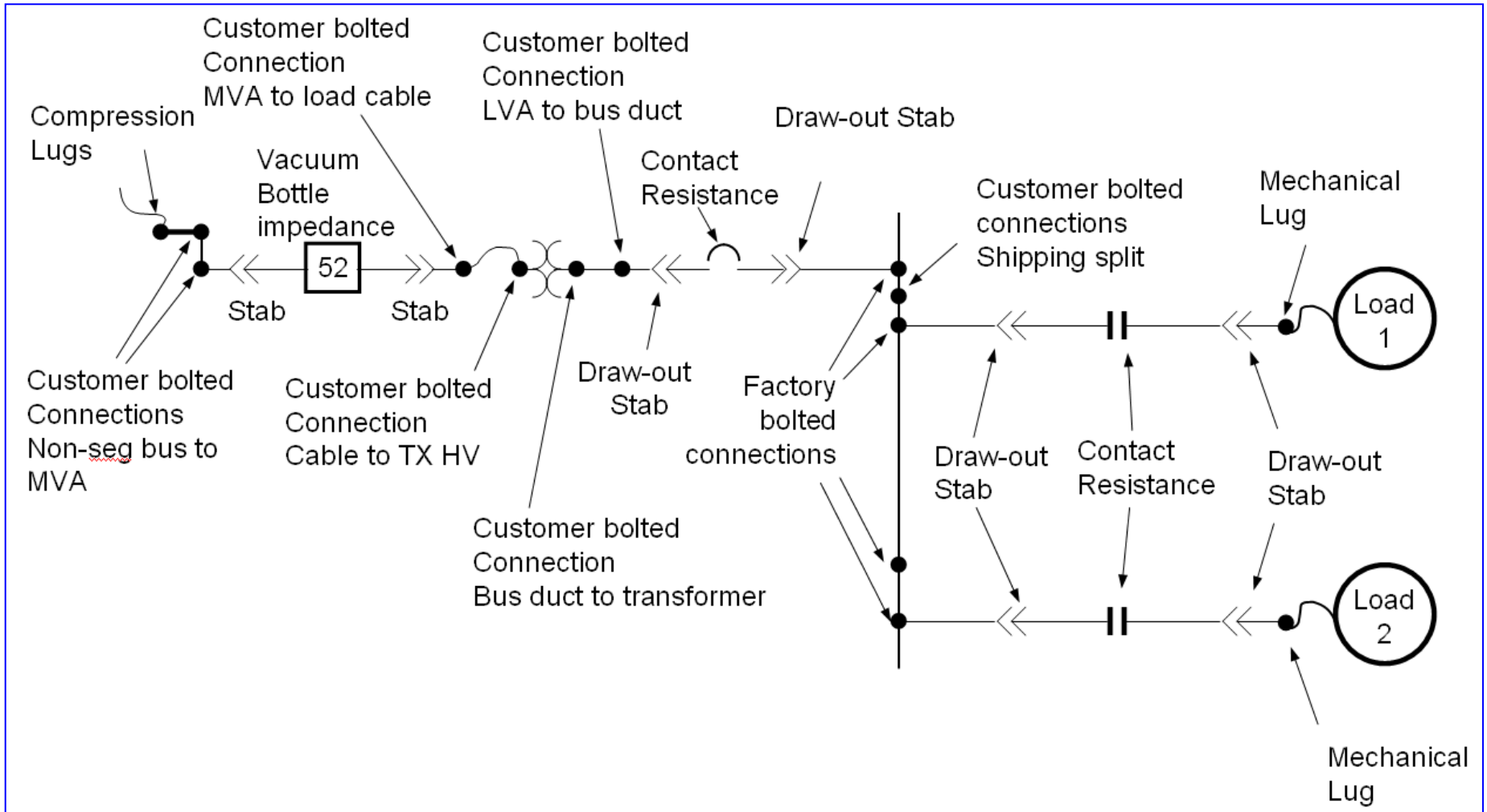

**Figure 2: Any pressure junction is a potential “hot spot”**

# Conductor Impedance is Fairly Static

- Extraction of actual  $Z = R + jX$  using upstream and downstream sampling of  $V$ ,  $I$  and deriving raw  $Z$  ( $V/I$ )
- As underlying  $Z$  is not changing quickly, oversample to extract - calculate multiple values of  $Z$ .
- Statistically process the oversampled data to extract the mode (most common value) for both  $Z$  ( $V/I$ ) as well as the phase angle between  $V$  and  $I$ . Solve for  $R$ .

# Simulation

---

- Built model that adds  $500 \mu\Omega$  to 1-phase circuit
- $I$  varies between 100 and 200 amperes.
- Parallel loads switch between 1200 and 2400 amperes.
- Added odd ( $3^{\text{rd}}$ ,  $5^{\text{th}}$ ,  $7^{\text{th}}$ ,  $9^{\text{th}}$ ) harmonics
- Added transients
  - Parallel load switching

# Simulation

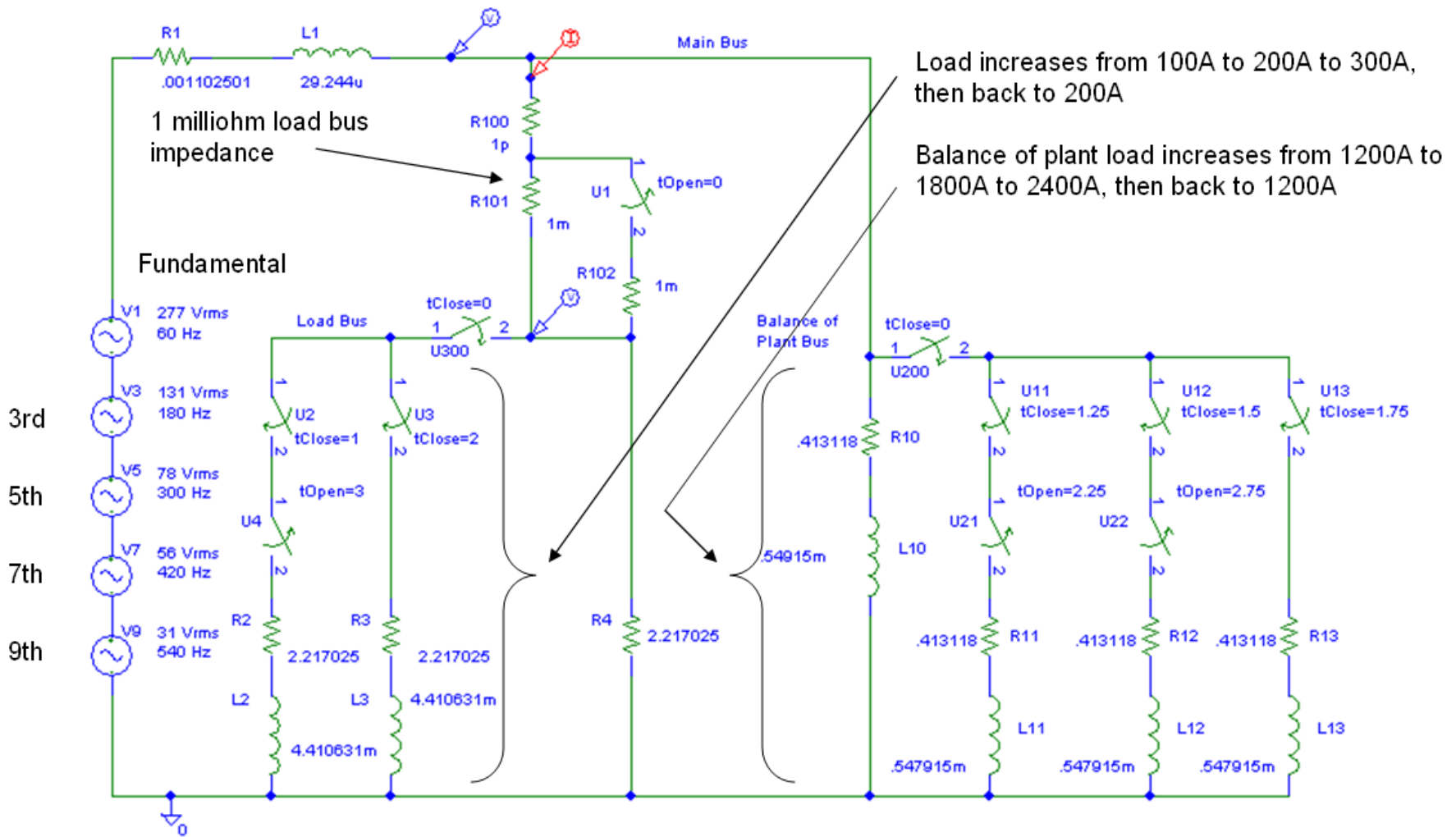

Load increases from 100A to 200A to 300A, then back to 200A

Balance of plant load increases from 1200A to 1800A to 2400A, then back to 1200A

# First Part of Filtering Algorithm

- Double precision floating point data from SPICE output imported to program to “quantize” the results into only numbers that could be represented by an arbitrarily chosen A/D for V and I inputs.
- Oversampled and solve for Z:
  - Mode algorithm:
    - If  $Z_{\text{sample}} > Z_{\text{mode}}$ 
      - then  $Z_{\text{mode}} = Z_{\text{mode}} + (\text{Gain})$
    - If  $Z_{\text{sample}} < Z_{\text{mode}}$ 
      - then  $Z_{\text{mode}} = Z_{\text{mode}} - (\text{Gain})$



# Correct Identification of Change

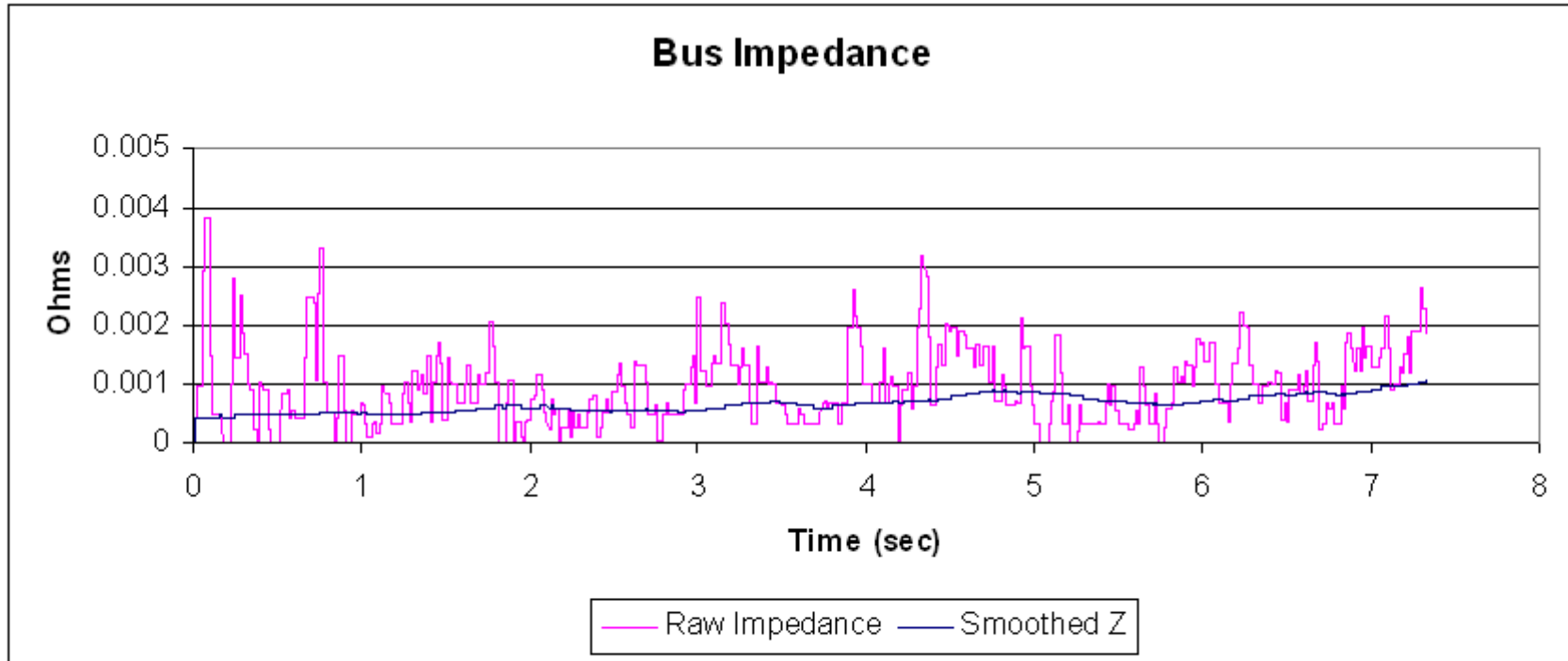

After 7 seconds, the value settles to 1 milliohm, the correct value. This is with an 8-bit A/D resolution!

# Bench Test

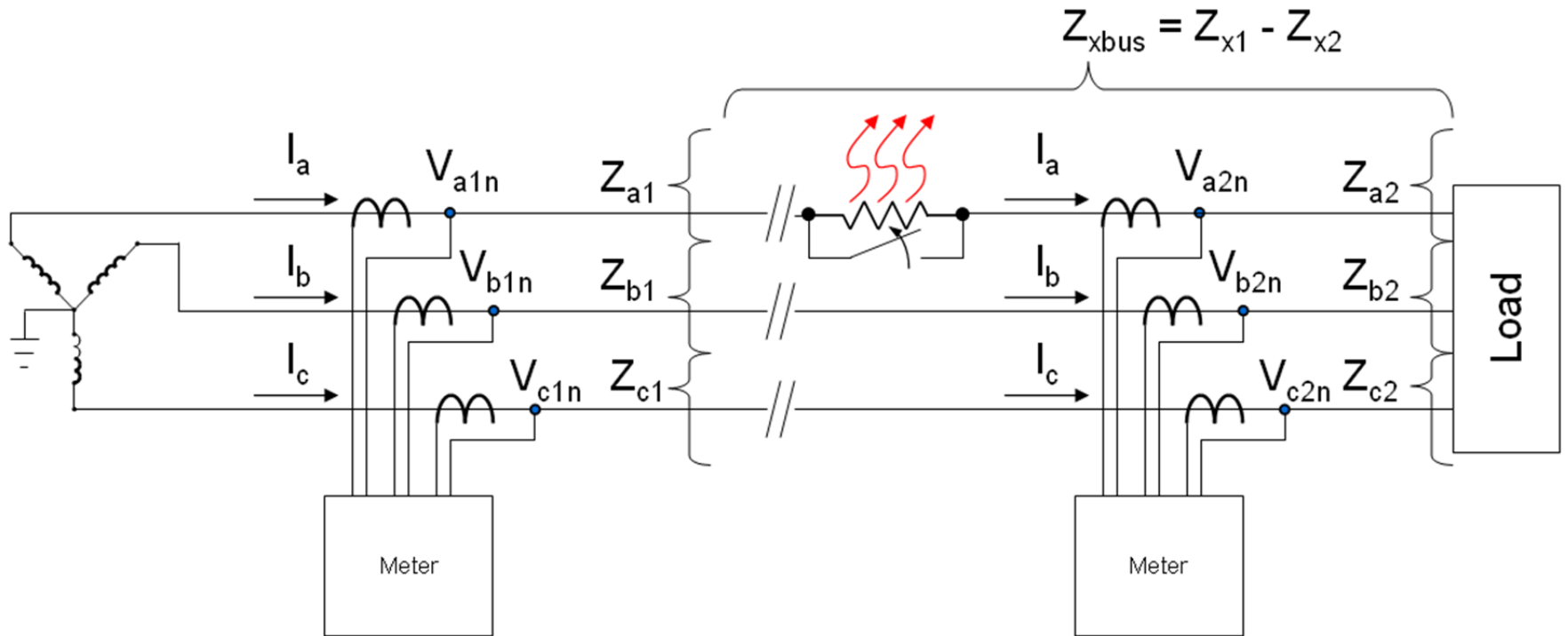

**3-phase test setup showing selectable 500  $\mu\Omega$**

# Difficult to See Change

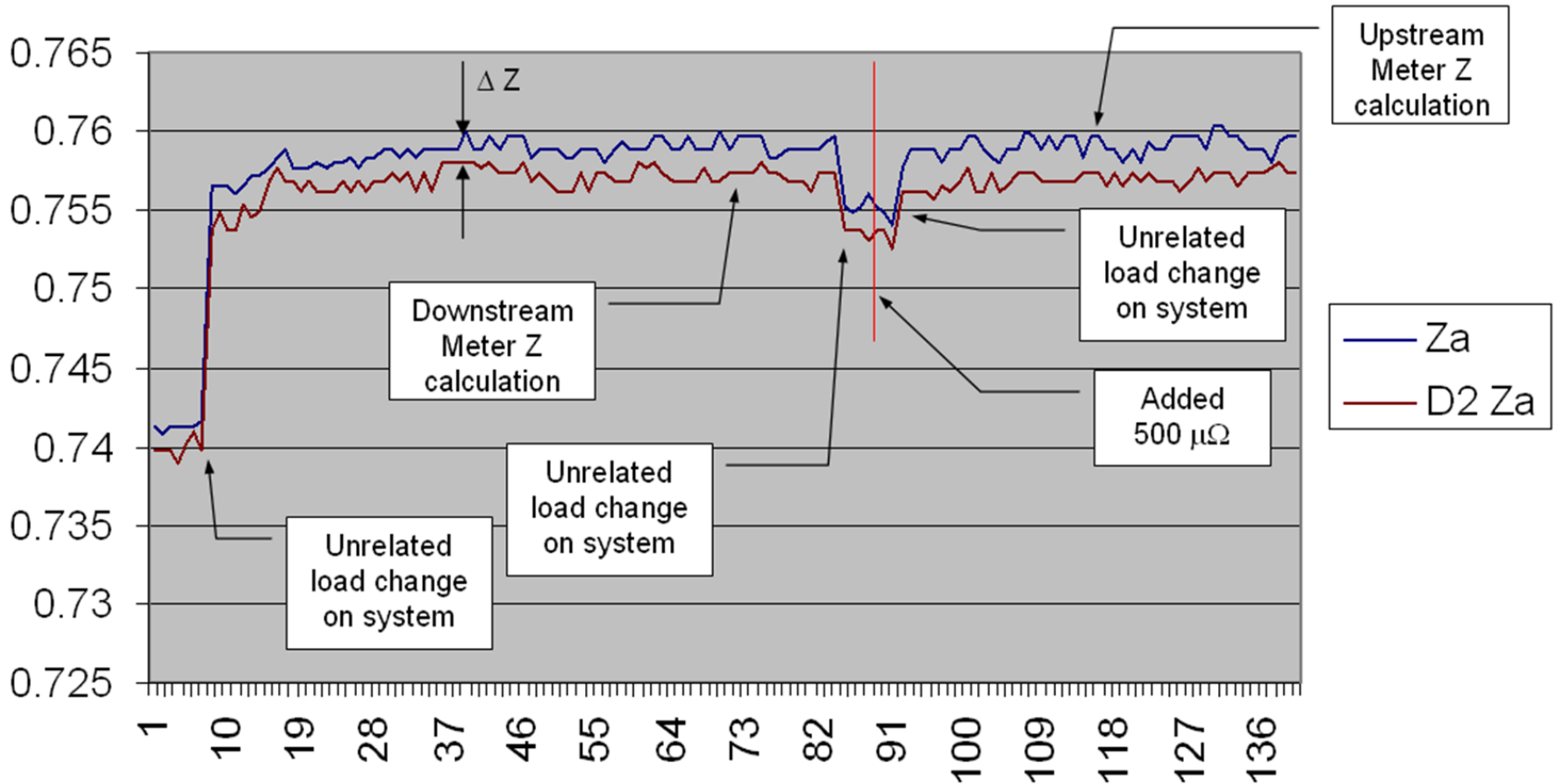

# Post Filtering: Data Visible

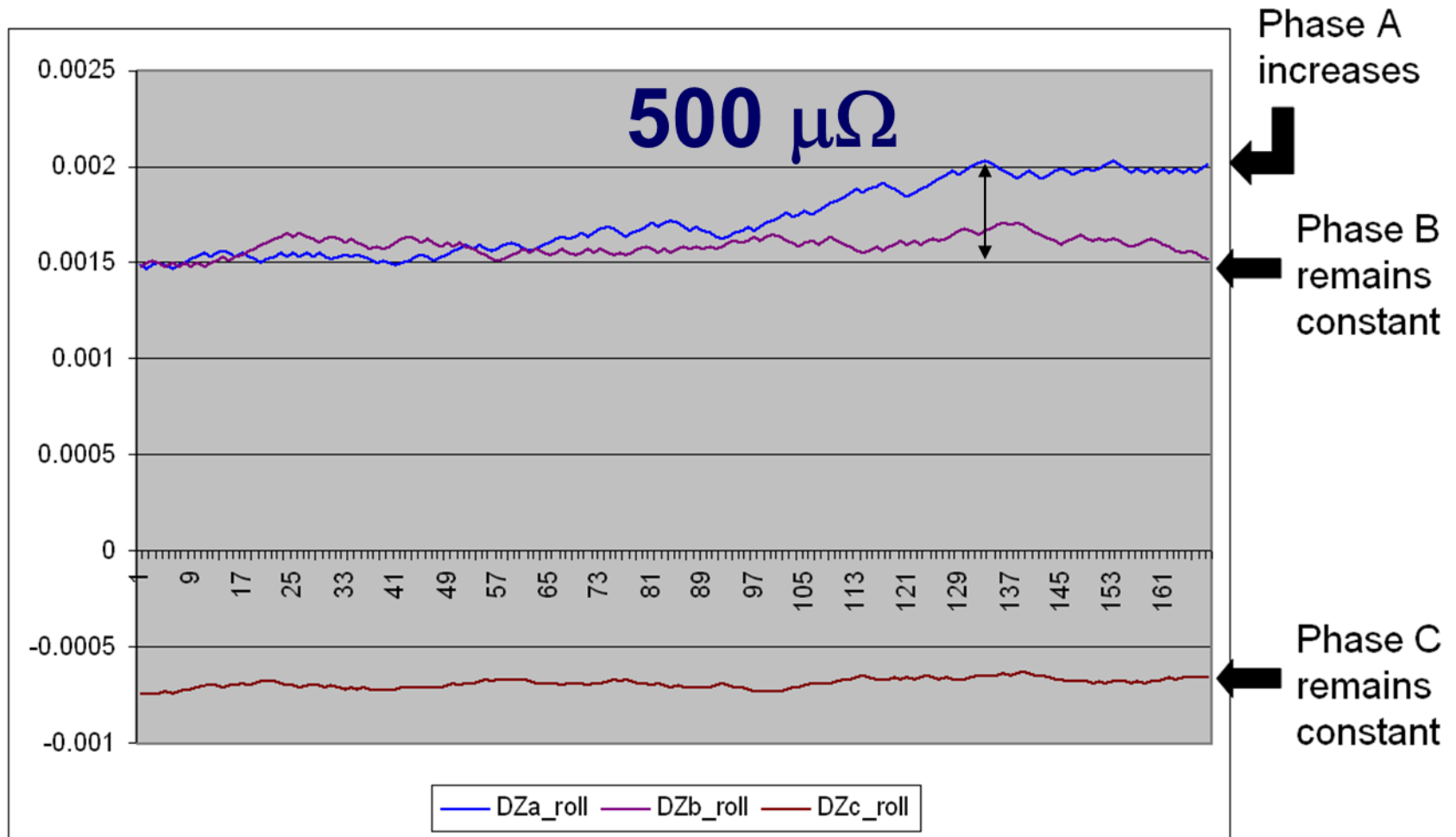

# Conclusion

---

- Oversampling and statistical processing of power systems data results in measurement of signals that are normally hidden.
- Hidden problems caught early improve reliability

**EATON**

*Powering Business Worldwide*